



STORM WORK

USER MANUAL REV 0.2

DOC-000474(3)

Issue date: 01-Dec-2019

Original Instructions are English Version



Contents

1	Introduction.....	3
2	Product Specifications.....	4
3	Operational guidance.....	5
3.1	General features.....	5
3.2	Pre-use procedures.....	5
3.4	Instructions as per BS EN 14502-1:2010.....	6
3.4.1	Information for the user.....	6
3.4.2	Passenger Instructions.....	6
3.4.3	Information for the crane driver.....	7
3.4.4	Special requirements related to the work from the suspended basket.....	7
4	Inspection & Maintenance.....	8
4.1	Definitions.....	8
4.2	Inspection Types.....	8
4.3	Supporting Documentation and Equipment Marking.....	9
4.3.1	Customer drawing pack.....	9
4.3.2	Certification pack.....	9
4.3.3	Inspection Plate.....	9
4.3.4	Data Plate.....	9
4.4	Frequency.....	10
4.5	Storm-Work inspection and maintenance schedules.....	11
4.6	Load Test Procedure.....	12
4.7	Pre-use Inspection checklist.....	13
3.8	Thorough examination checklist form.....	15
4.9	Report of Thorough Examination.....	17
5	Handling & Storage.....	18
5.1	Stock Inspections.....	18
5.2	Shipping and storage.....	19
6	Replacement Parts.....	19
6.1	Kits.....	20
6.2	Parts identification.....	20
6.3	Accessories.....	20
7	Certificates.....	21
7.1	EC Attestation of Conformity.....	21
8	Contact Details.....	22
	Appendix I: Parts Identification drawing and Torque settings.....	23

1 Introduction

This manual contains information on the safe operation, inspection and maintenance of your STORM-WORK suspended work basket. STORM-WORK includes a range of novel features designed to enhance the safety of suspended access operations; these include:

- **Safe by design:** STORM-WORK has a high level of design redundancy in key load path components and only used safe and reliable methods of construction and high quality durable materials (such as Grade 316 Stainless Steel). All critical mechanical fasteners (e.g. threaded bolts and nuts) are visible, accessible and easy to inspect prior to use, to facilitate safe operation.
- **Anti-snagging** - The profile of the outer panels and flotation are designed to minimise snagging risks during lifting and when working close to other structures.
- **Soft contact** – Storm-Work’s flotation panels double as impact protection and provide a ‘soft contact face’ between the basket and adjacent structures, reducing the risk of damage to the STORM-WORK and other assets. The panels also create a safe work-space between side panels the adjacent structures.
- **Flotation** - In the event of immersion when working over water, the STORM-WORK will float and self-right. A safe space is provided where passengers may await rescue. Easy escape is possible both with and without an inflated life-vest.
- **Rigorous testing** - STORM-WORK has undergone the most rigorous testing applied in the offshore industry to ensure its operational performance meets design objectives.
- **Durability (low maintenance)** – STORM-WORK has a weld-free critical load path and uses marine grade 316 stainless steel for all main structural components safe, durable low-maintenance product.

Safe use of the STORM-WORK is the responsibility of the user, who should ensure that operations are conducted in accordance to industry best practice and applicable legal standards. Appropriate training is recommended prior to the use of this device and may be provided by Reflex Marine on request.

If you need any support or advice on the safe use of this product, please contact Reflex Marine via www.reflexmarine.com/support Additional copies of this manual and other guidance may be downloaded from the same location.

All information disclosed in this document is the property of Reflex Marine Ltd except where otherwise stated. Reflex Marine Ltd reserves all patent rights, design rights, manufacturing rights, copyright and sales use rights thereto, and to any article disclosed within this document except where such rights are expressly granted to others or where not applicable to vendor proprietary parts.

© 2019 Copyright Reflex Marine Ltd, All rights reserved.

2 Product Specifications

Table 1 - Product Specifications

Model No.	-	RA0602
Dimensions (Nominal)	Length	1690 mm
	Width	1215 mm
	Height	2330 mm
	Interior height	2110 mm (>2m as per EN14502-1)
Weight & Safe Working Load	Maximum Gross Mass	850 kg
	Tare Weight	350 kg
	Payload - SWL	500 kg Four passengers (plus luggage)
Materials	Frame	316 stainless steel, A4 stainless fixings
	Central column / load plate	316 duplex stainless
	Other components	All stainless except GRP floor and roof grating
	Buoyancy	Polyethylene. Polyurethane (PU) closed-cell foam fill.
	Landing feet	Natural rubber - Shore 65
Operating Temperature	-	-20°C to +50°C
Impact protection	Lateral impacts	Tested up to 2 m/s
Anti-snagging		Tested in a range of snagging scenarios.
Fall protection	Personal fall protection equipment	Anchor points as per EN 795
Overhead protection	Protection from dropped objects	Tested with 7kg ball dropped from 2m
Immersion protection	Floating & self-right	Tested in a full range of loading scenarios.
Stability	Lifting / inclination	<7° with 1.5x SWL worst position (EN14502-1)
	Submerged self-righting	Up to 180° inverted to the vertical position
Verification	Attestation of conformity	BS EN 14502-1 Cranes – Equipment for the lifting of persons. Part 1: Suspended baskets
Quality	System	Manufactured to ISO 9001:2008
Design Standards	National standards	UK, BS EN 1993 series: 'The Use of Structural Steel in Building'
	European Standards	EC Machinery Directive EN 14121-1, BS EN 12100-10 Load Test – ILO152 / LOLER
	National Regulations	UK, PUWER / LOLER

3 Operational guidance

3.1 General features

The STORM-WORK suspended work basket is designed for the lifting of persons by crane to elevated positions from which they can conduct industrial work activities. It is designed to meet standard BS EN 14502-1 Cranes – Equipment for the lifting of persons. Part 1: Suspended baskets. Under EN 14502-1 there are also obligations for the user, referring to national legislation and practice which sets out conditions under which such exceptional use is permitted, the measures that must be taken to ensure the safety of the operation and technical requirements for the equipment use.

3.2 Pre-use procedures

This document does not set out any detailed procedures for the management of lifting operations. Sources on these matters can be found in many national and international standards such as those listed below:

- DOE STD 1090 2007 Ch 4 Lifting Personnel;
- ASME B30.23 Personnel Lifting Systems;
- Lifting Operations and Lifting Equipment Regulations 1998 (LOLER);
- Offshore personnel transfer by crane best practice guidelines MTF, May 2016.

Site specific risks shall be considered by the user – i.e. use of power tools or hot work equipment and subject to job specific planning and risk assessments.

- i. **Pre-job planning** - A designated leader shall be appointed for the entire personnel lifting operation and shall prepare a work plan for the operation.
- ii. **Operation (site) specific considerations** – Any site or operationally specific risks shall be considered. e.g. adjacent hazards, lifting restrictions, use of power tools, hot work etc.
- iii. **Pre-lift meeting** - A pre-lift meeting to review procedures and plans shall be held and attended by the designated leader, crane operator, ground crew, signallers and persons to be lifted.
- iv. **Trial lifts** - Where applicable a trial lift should be conducted to confirm the safety of the lift plans with a similar payload to that planned for the operation.
- v. **Pre-lift inspection** - Prior to lifting personnel, a visual inspection shall be performed by a competent person(s) of the crane, rigging, access basket and the local area. A full set of inspection and maintenance schedules for the Storm-Work is included in section 3 of this manual.

3.4 Instructions as per BS EN 14502-1:2010

Guidance below is recommended as per section 7 of BS EN 14502-1:2010 Cranes – Equipment for the lifting of persons, Part 1: Suspended baskets.

3.4.1 Information for the user

- i. The crane and suspended basket shall only be operated by persons trained in the safe use of the combination, including the operating procedures for egress in case of power supply failure or control failure.
- ii. The lifting should be performed in controlled conditions under the direction of one appointed person.
- iii. A crane operator should always be present at the normal crane control station whilst the basket is occupied. Two-way communication should be available between persons in the basket and the crane operator at all times during the lifting operation.
- iv. The required equipment necessary to perform an emergency rescue shall be available throughout the lifting operation.
- v. During operation the person in charge shall not require the crane operator and signaller to do other work at the same time.
- vi. Load lifting attachments for suspended baskets shall not be used for any other purpose.
- vii. Suspended baskets shall not be used in high winds, storms, ice, snow, fog, sleet, or other adverse weather conditions which could affect the safety of personnel.
- viii. Machines which can be operated simultaneously in the same place with risks of collision shall be stopped.
- ix. Unintended movement of the basket should, where possible, be prevented, e.g. by means of guide ropes or anchoring.
- x. The suspended baskets and all associated lifting equipment should be inspected prior to each use.
- xi. If suspended baskets are moved through openings, measures shall be taken against entanglement and crushing risks.

3.4.2 Passenger Instructions

- i. The basket should be positioned on a firm surface during access and egress.
- ii. The load in the basket should be as evenly distributed as possible.
- iii. Persons in suspended baskets should fasten their safety harness onto the anchorages provided. The length of the device between the anchorage points and the harness should ensure the occupants are restrained within the basket. The maximum length shall be indicated in the instruction notice of the manufacturer.
- iv. Occupants shall keep all parts of the body inside the suspended basket during raising, lowering and positioning, to avoid pinch points.
- v. The basket rated capacity shall not be exceeded.
- vi. Tools and material carried by personnel should be secured, in particular against displacement, tipping, and falling out.
- vii. Occupants should not stand on or work from the handrail or side protection of the suspended basket or anything in it.

3.4.3 Information for the crane driver

- i. All movements should proceed gently with low speeds.

3.4.4 Special requirements related to the work from the suspended basket

- i. Any power cables or hoses provided to the basket should be connected in such a way that they will not interfere with the safe operation of the basket.
- ii. Any guide ropes provided to the basket should be connected in such a way that they will not interfere with the safe operation of the basket.
- iii. Power cables or hoses should not be used as guide ropes.
- iv. When electric welding from the basket, special care should be taken to earth the basket in order to protect the crane and/or its ropes from becoming conductors of electricity.
- v. Storm-Work is not specifically designed for the conduct of hotwork. If it is used for this purpose the User should take adequate precautions, including proper shielding of the plastic components from the sources of heat.

4 Inspection & Maintenance

4.1 Definitions

- **Critical Parts** - These are defined as the key structural (load-bearing) components which keep the basket safely suspended.
- **Competent Person** – A person with appropriate practical and theoretical knowledge and experience of the equipment. This shall enable them to detect defects and weaknesses and to assess their importance in relation to the safety and continued use of the equipment. A competent person must be sufficiently independent and impartial to allow objective decisions to be made.

4.2 Inspection Types

Table 3 Inspection Types

Inspection Type	Description
Pre-use check	A visual check of key areas prior to each use without dismantling the assembly.
Thorough Examination	<p>A careful assessment of the components, This may include dismantling assemblies to assist visual assessments components and may be supplemented by other means such as measurement and non-destructive testing.</p> <p>The examination of the lifting assemblies should include an assessment of the condition of each leg.</p>
Post Load Test	A test under a defined load, followed by a thorough assessment of components in the critical load path.

All inspections should be:

- i. Performed as per the frequency indicated in Section 4.5 and summarised in Table 4;
- ii. Performed by a competent person;
- iii. Formally recorded in a Thorough Examination checklist, Section 4.8;
- iv. Completed with issuance of Report of Thorough Examination, Section 4.9.

4.3 Supporting Documentation and Equipment Marking

4.3.1 Customer drawing pack

Every Storm-Work is provided with a **customer drawing pack** that contains all the relevant drawings and procedures. The customer drawing pack can be found in the appendices of this manual and contains the following:

- i. Assembly drawings
- ii. Bill of materials
- iii. Replacement parts, kit drawings
- iv. Torque settings

4.3.2 Certification pack

Storm-Work is provided with a certification package, which includes, but is not limited to: the manufacturer's Declaration of Conformity and ISO 9001 certificate; proof load test certificate; a certification summary for all critical parts - with particular importance to the wire rope lifting assembly.

If any further certification is required, please contact REFLEX MARINE.

4.3.3 Inspection Plate

An inspection plate will be issued and attached by the test house, which should show:

- i. The owner of the equipment.
- ii. The unique serial number of the equipment.
- iii. Maximum gross mass (kg)
- iv. Tare weight (kg)
- v. Test weight (kg)
- vi. The dates of inspections, where the following prefix can be used to denote inspection type: E – Examination, T – Load test.

4.3.4 Data Plate

A data marking plate will be issued and attached to the unit at manufacture.

Note: *When a carrier enters service or is placed into the operating environment, this date must be stamped onto the unit Data plate, as per item iv.*

- i. Model number of the equipment.
- ii. Unique serial number of the equipment.
- iii. Date of manufacture.
- iv. Date equipment is put into service.
- v. Maximum gross mass (kg / lbs)
- vi. Tare weight (kg / lbs)
- vii. Rated capacity / Safe working load (kg / lbs)
- viii. Maximum number of passengers: 4

4.4 Frequency

Reflex Marine recommended frequency for inspection and examinations is based on the UK's LOLER 1998 guidance, where:

Thorough examination should be conducted:

- i. before lifting equipment is put into service for the first time, unless the lifting equipment is in as-new condition with no sign of previous use, or transport or handling damage **and** the manufacturer's Declaration of Conformity was made less than 12 months before the planned first in service date.
- ii. at least every 6 months.
- iii. if there is any concern over heavy impacts, overloads, or if lifting equipment is exposed to conditions causing deterioration which is liable to jeopardise the safety of the equipment.
- iv. if the equipment, in whole or in part, has been disassembled and reassembled.

Where the basket has experienced heavy impacts, or sustained substantial damage, a detailed examination should be carried out before conducting any further lifts. Details of any damage and its cause (if known) should be recorded in a damage report.

If damage to the frame has occurred, welds, mechanical fasteners, and structural sections should be examined for cracks using the dye penetrant method.

Details of all repairs or modifications carried out should be recorded and copies of damage and repair / modifications reports should be sent to the party controlling the use of the equipment.

Contact REFLEX MARINE or one of our Approved Service Centres for technical advice on inspection, testing or maintenance. It is always helpful to provide detailed photos and reports along with any query to operations@reflexmarine.com

4.5 Storm-Work inspection and maintenance schedules

These recommendations follow a prudent approach to ensuring equipment integrity for safety critical **personnel lifting equipment**.

As usage varies widely between different regions and operations a conservative approach is considered necessary to ensuring minimum standards are met.

Table 4 - Storm-Work inspection and maintenance recommendation

Storm-Work recommended inspection and maintenance schedules (when equipment is deployed into service environment)					
Usage Category No of Lifts per 6 months	Pre-use inspection	Thorough examination	Wire rope sling replacement	Periodic parts replacement and load test ³	Life extension or replacement ^{1,2}
Low < 100	Prior to every use	6 months	12 months	3 years	12 years
High > 100	Prior to every use	3 months	6 months	2 years i.e. For >400 lifts in 2 years.	8 years

¹ This may be extended subject to a 'condition & service assessment' carried out by Reflex Marine or an Approved Partner.
² If the usage of a basket varies then we suggest a replacement at the end of the third cycle of periodic parts replacement.
³ On completion of load test equipment should undergo additional thorough examination to check no damages have occurred.

4.6 Load Test Procedure

Table 5 - Load Test Requirements

Question	Response
When should a Proof Load Test be conducted?	<ul style="list-style-type: none"> i. After replacement of any critical parts. <i>Note: Does not apply to replacement of lifting assemblies.</i> ii. After any suspected damage arising from overloading or impact. iii. If the history of the unit is uncertain. iv. If the inspection data plate is missing, illegible or out of date.
Who should conduct this test?	<p>A competent person shall carry out any Thorough Examination. Assessment of competency shall be based on knowledge of the equipment, defects and their causes, methods of testing and fault diagnosis.</p> <p>The competent person can be in-house (if they are considered sufficiently independent) or from an external organisation such as a Certification Authority.</p>
Does this test require a formal record?	Yes. Issuance of Report of -Thorough Examination / test certificate and update marking of inspection plate.
What equipment is required to perform this test?	<ul style="list-style-type: none"> i. Loading weights or sand bags (1350 kg). ii. Certified weighing scale or load cell. iii. Lifting equipment certified for rated load.

Table 6 - Load Test Instructions

Item	Instruction
Components Under Test	<ul style="list-style-type: none"> i. Wire rope lifting assembly/ lifting point ii. Main load bearing assemblies.
Basis of Test Proof Load	Twice Maximum Gross Mass, less Tare Weight* 2 x 850 kg – 350 kg = 1350 kg
Test Proof Load Distribution	1350 kg (2976 lb) placed on the floor and distributed evenly.
Crane Hook Load	1700 kg (3748 lb)
Test Method	Lift the unit and hold static for 3 minutes.

* **Note: The tare weight of the Storm-Work is approximately 350 kg (772 lb) but may vary slightly. Each unit must be weighed prior to load test**

4.7 Pre-use Inspection checklist

Next page

PRE-USE INSPECTION CHECKLIST

1	Check the INSPECTION PLATE and all CERTIFICATION are in order.
2	Check the WIRE ROPE LIFTING ASSEMBLY is correctly attached and in good order. Check SHACKLE safety bolts are fitted with split pins.
3	Check LIFTING POINTS and LIFTING PLATES are secure and in good condition.
4	Check all COLOUR-CODED SAFETY BOLTS along the load bearing assembly are secure and in good condition.
5	Check the FALL RESTRAINT ANCHOR POINTS are secure and in good condition.
6	Check all other FITTINGS, FRAME, and BUOYANCY are secure and in good condition.
7	Check the FLOOR GRATING and ROOF GRATING and all fasteners are secure and in good condition
8	Check the DOORWAY and LATCH are secure and in good condition.

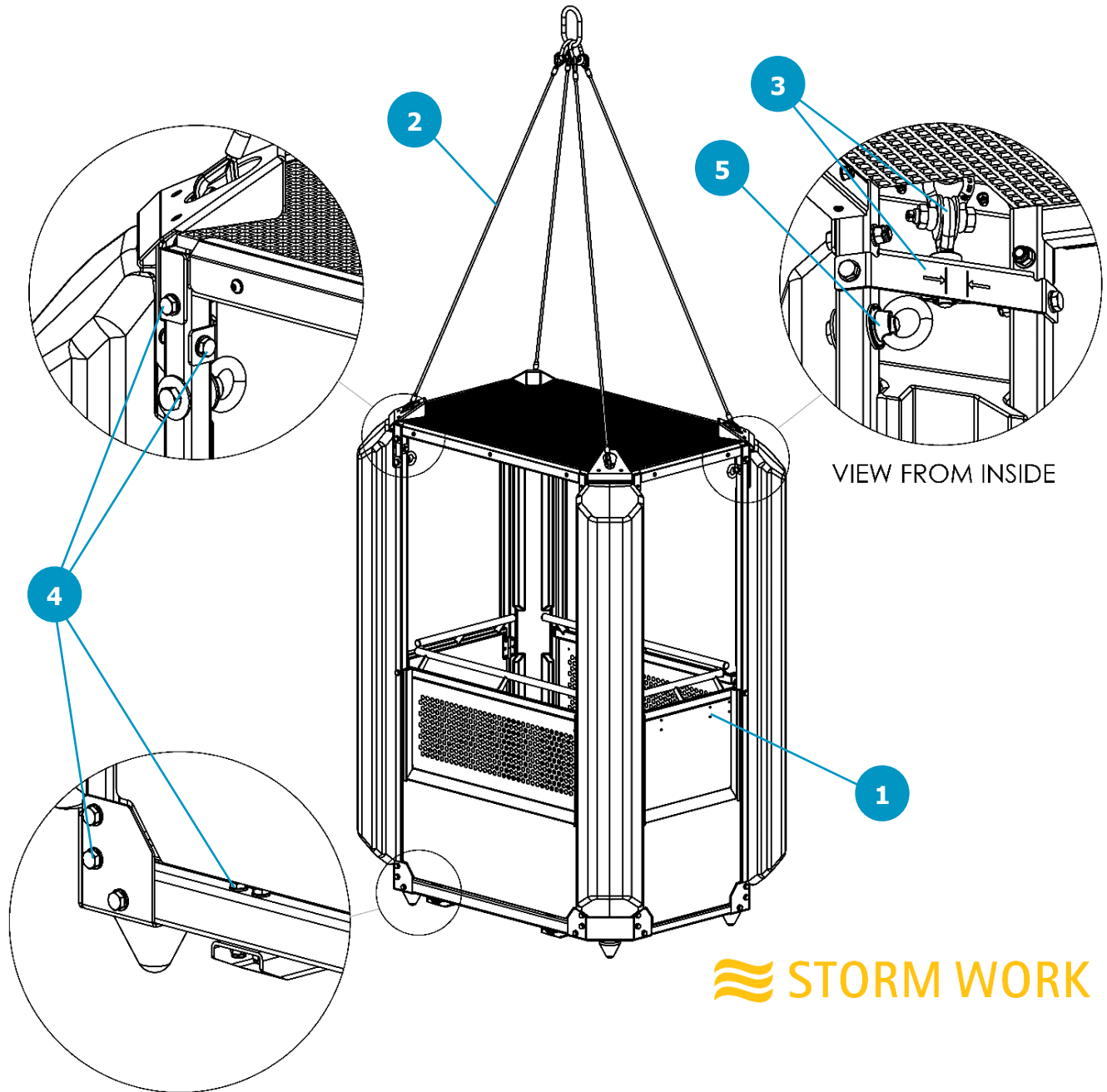

 **STORM WORK**

4.8 Thorough examination checklist form

Storm-Work thorough examination checklist (Page 1/2)			
Unit serial no.		Examination date	
Location		Inspected by	
Owner/Company address		Position/ Company	
Service report number		Signature	
<ul style="list-style-type: none"> Refer to Appendix I of this manual for Parts identification/ BOM RA0579 and Torque settings RP0604. Safety Critical (Structural) parts are highlighted <u>red underlined</u>. 			
Item No.	Description	Pass/ Fail/ Notes	
1.	<p><u>Wire Rope Lifting Assembly:</u></p> <p>Check that the lifting assembly is attached correctly, and in good condition. Irrespective of condition lifting assembly should be replaced at least every 12 months.</p>	Unique I.D.:	
2.	<p><u>Lifting eyebolts [p/n RP0616]:</u></p> <p>Visually inspect the lifting point for any signs of damage or strain. Ensure fasteners are tight and fully secure. Replace colour-coded safety bolts as per periodic part replacement schedule. Section 4.5</p>	Colour-code: Torque:	
3.	<p><u>Load plate and M12 colour-coded safety bolts [p/n 112-065-HB-4]:</u></p> <p>For each corner lifting point visually inspect the 4 safety bolts for any signs of damage or strain. Visually inspect the load plates and columns for signs of damage or strain. Replace colour-coded safety bolts as per periodic part replacement schedule. Section 4.5</p>	Colour-code: Torque:	
4.	<p><u>Lower corner plate and M12 colour-coded safety bolts [p/n 112-070-HB-4]:</u></p> <p>For each corner visually inspect for any damage and ensure that all bolts and fasteners are tight and fully secure. Replace colour-coded safety bolts as per periodic part replacement schedule. Section 4.5</p>	Colour-code: Torque:	
5.	<p><u>Floor support beams and M10 colour-coded safety bolts [p/n 110-080-HB-4]:</u></p> <p>For both beams visually inspect for any damage and ensure that all bolts and fasteners are tight and fully secure. Replace colour-coded safety bolts as per periodic part replacement schedule. Section 4.5</p>	Colour-code: Torque:	
6.	<p><u>Fall restraint anchor points and M16 fixing screw [p/n 116-070-HS-4]:</u></p> <p>For each anchor point visually inspect for any damage and ensure that all bolts and fasteners are tight and fully secure.</p>	Torque:	
7.	<p><u>Outer frame, side panels, and buoyancy:</u></p> <p>Visually inspect for any damage and ensure that all bolts and fasteners are tight and fully secure.</p>		
8.	<p><u>Doorway, latch, and latch plate:</u></p> <p>Visually inspect for any damage, ensure the doorway opens and closes securely, and ensure that all bolts and fasteners are tight and fully secure.</p>		
9.	<p><u>Floor grating and roof grating:</u></p> <p>Visually inspect for any damage and ensure that all bolts and fasteners, and securing plates are tight and fully secure.</p>		

Storm-Work thorough examination checklist continued... (Page 2/2)				
Item No.	Description	Pass/ Fail/ Notes		
10.	<p>Landing Feet: Ensure feet are in good condition and properly secured to the capsule. <i>Note : Minimum height of foot (ground to underside of lower corner plate) = 80mm.</i></p>	h1:	h2:	
		h3:	h4:	
11.	<p>Stickers: Check stickers on the unit are in good condition and that none are missing or damaged. The sticker location drawing can be found in Appendix I.</p>			
12.	<p>Inspection plate: Update inspection plate to show date Thorough Examination was completed. (Stamp letter E and date)</p>			
Load test				Notes
13.	<p>Load Test: With the exception of the Wire Rope Lifting Assembly, after replacement of any critical parts a load test must be conducted to verify the structural integrity of the equipment. See section 4.6 of User Manual.</p>			
14.	<p>Post load test thorough examination: Conduct and report a post load test thorough examination. Update inspection plate to show date Load Test was completed. (Stamp letter T and date)</p>			
Other				Notes
15.	<p>Clean : Has the unit been cleaned? (fresh water/ mild detergent)</p>			
16.	<p>Documentation :</p> <ul style="list-style-type: none"> a. Report (Certificate) of Thorough Examination. (ROTE) b. Load test certificate c. Service report: examination checklists and photographic record. d. Certificates for replacement parts. 			
NOTES (OBSERVATIONS/ ACTIONS):				
Unit serial number:			Inspected by:	
				Examination date:
Is this equipment safe for use? (YES/ NO)				

4.9 Report of Thorough Examination

A Report of Thorough Examination should be completed and issued on completion of service work (see example below). Note: This certificate is based on UK LOLER 1998 SI 2307 requirements, but other certification standards may take precedence in different regions.

REPORT OF THOROUGH EXAMINATION

This report complies with the requirements of Lifting Operations and Lifting Equipment Regulations – SI 2307

Report number:	
Thorough examination date:	

Date of last thorough examination:	
Report number of last examination:	

Name and address of Employer for whom the thorough examination was made:		Address of premises at which the examination was carried out:	
Client ref / P.O.:		Works / Call-out no:	

Unique i.d. no.	Date of manufacture	Description of equipment and scope of work and tests conducted	W.L.L.	Proof load applied

Details of defects which present a hazard to persons: (if none state NONE)

Details of defects which do not present a hazard to persons: (if none state NONE)

Details of any repair, renewal or alteration required to remedy defects identified above:

Is this equipment safe to operate?	Yes / No
Date of next thorough examination:	

Company appointed examiner:	
Qualification of company appointed examiner:	
Signature:	
Authorising person/ position/ signature on behalf of Company	
Date of issue	

5 Handling & Storage

5.1 Stock Inspections

These guidelines are for the stocking of new units and parts before they are put into service. These guidelines are **not** applicable to units and parts that have already been put into service.

Table 7 – Stock inspection recommendations

Stock Part	In Stock Inspection	Stock Release Inspection	Certification/ Marking	Storage actions
Suspended work baskets	Thorough examination: Every 12 months	Less than 3 years: Thorough examination Greater than 3 years: Load test and Thorough examination	1. Thorough examination date to be stamped on inspection plate; 2. Thorough examination checklist to be completed; 3. Report of Thorough Examination to be issued.	1. Remove lifting assembly 2. Place lifting assembly into clean, dry storage 3. Ensure the unit is chocked up off its feet, stored in a secure area away from the risk of damage and protected from exposure to the elements.
Wire rope lifting assembly/ Wire rope slings	Thorough examination: Every 6 months	Thorough examination	1. Report of Thorough Examination to be issued.	1. Store off the ground in clean, dry and ventilated storage area with any lifting assembly cover removed.
Other replacement parts (not lifting assemblies)	None	Thorough examination	Not required	1. Store in clean, dry storage.
Note: When a carrier first enters service, the “In service date” must be stamped onto the unit Data plate .				

5.2 Shipping and storage

- i. **Transit inspections** - Before and after transportation the carrier should be inspected to check for damage sustained in transit. The unit must not be used if any structural damage is observed. If any damage has been observed a thorough examination should be carried out to determine the extent of the damage.
- ii. **Lifting assembly (slings)** – Particular care should be taken to ensure that the slings are protected from damage and degradation during transit and storage. It is recommended that they are secured in a protected position by plastic tie wraps.
- iii. **Protective cover** - It is recommended that the carrier is covered for shipping either with an OEM supplied protective cover or other heavy-duty tarpaulin material prior to road transportation.
- iv. **Handling during transportation** - The STORM-WORK can be handled by **forklift** either by lifting under the floor or the roof. Care should be taken when handling to avoid damaging any components. When **handling the carrier by crane** with short chain or strop, line or shackle should not be fitted through the thimbles/ hard eyes of the sling as this may deform the thimble.
- v. **Containerisation** - The STORM-WORK will fit upright in a high-cube container or laid flat (on its side) in a standard shipping container. If it is transported on flat rack it should be secured. Recommended securing points are the across the floor (through space in side panels) or across the handrails.
- vi. **Marine deck fastening** - Straps may be placed across hand rails or across the floor / between the side panels. Care should be taken not to over tighten and cause damage to the unit. Do not secure over doorway.
- vii. **Storage** – STORM-WORK is designed to cope with the harsh conditions on an offshore installation or vessel; however, it is important to protect the unit as much as possible from any hazardous elements and UV degradation. It is recommended that the STORM-WORK is stored under a cover whilst not in use.
- viii. **Storage of replacement parts** - Parts should always be stored in clean, dry, dust free environments and be suitably labelled and tagged.

6 Replacement Parts

The Storm-Work is a safety critical item and only genuine Original Equipment Manufacturer´s (OEM) parts should be used. This is of particular importance for the lifting (sling) assembly due to its very specific bespoke design for this application.

Replacement parts can be supplied as individual items or as appropriate kits. Prior to ordering any replacement parts or kits, establish the serial number which is stamped on the data plate. The serial number is SW4- XXX where XXX represents a three-digit number.

Reflex Marine holds replacement parts and accessories in stock. It may be advisable to hold an inventory of frequently replaced parts. This will help to ensure the continued safe operation of the carrier. Minimum stock quantities shall be influenced by:

- i. Remoteness of location
- ii. Downtime implications
- iii. Usage
- iv. Customs processing time
- v. Delivery cost for small parts

Reflex Marine can recommend stock items and quantities for your operation.

6.1 Kits

The following kits are available for routine and non-routine maintenance. Ordering an appropriate kit is more economical than replacing individual parts.

Kit Name	Part Number	Contents
Lifting Assembly	RA0528	4 leg Wire Rope Lifting Sling
Critical Parts Kit	RA0641	Lifting eye bolts Fasteners on structural load path
Landing Foot Kit	RA0736	4 X Feet plus Associated Fixings
Full Service Kit	TBC Contact Reflex marine	1x Lifting Assembly Kit 1 X Replacement Parts Kit 1 X Landing Foot Kit

6.2 Parts identification

Each assembly or part is assigned a part number which provides the unique identification of the part /assembly.

Where material grades and material traceability are deemed to be safety critical these components will be allocated unique component numbers which will be stamped or etched as required.

For bolts, where etching is impractical, batches will be colour coded and a note added to the mill certificate to identify the colour used.

6.3 Accessories

The following accessories are available from Reflex Marine to maximise operational effectiveness. They can be supplied with the carrier or ordered separately.

Strobe Light



Provides greater visibility at night and in poor weather conditions. High-intensity: light weight, waterproof to 300 m, Flash Rate 50 per min and also provides 6-mile visibility. Battery powered, fitted to the side panel of the STORM-WORK.

Note: This strobe is not certified for use in hazardous areas. A zoned strobe light is available on request.

Cover



A protective cover made from flame resistant fabric (BS7837) and protects against UV degradation, weather, and contaminants.

For a complete list of accessories please contact REFLEX MARINE

7 Certificates

7.1 EC Attestation of Conformity



Product Service

Choose certainty.
Add value.

Attestation of Conformity.
No: 30244

Holder of Certificate: Reflex Marine Ltd.

Location of Equipment: Old School House
School Hill
Shortlanesend
Truro
Cornwall
TR4 9DU

Product / System: Storm Work Basket.

Test / Assessment Reports: As per BS EN 14502-1. Assessment report held on file (75940069)

Standards: BS EN 14502-1 Cranes. Equipment for the lifting of persons. Suspended baskets

Technical Documentation File Identify: 30244 / 75940069

This attestation of Conformity is issued on a voluntary basis according to Council Directives 2006/42/EC related to Machinery. It confirms that the listed equipment, which is not listed under Annex IV of Directive 2006/42/EC, complies with the protection requirements of the listed Directive. It refers to the sample submitted for testing and inspection and only relates to this sample in the build state and configuration at the time of test/ inspection.

The CE marking may be used on the equipment described above subject to the equipment meeting the requirements of all applicable Directives, and the issue of all necessary documentation including the Declaration of Conformity

Date: 08 November 2018

Drawing status

Released

TUV SUD Product Service is the trading name of TÜV SÜD Ltd. Registered in Scotland. Company Number – SC215164

Managing Director
Brjan Austin

Tel: +44 (0) 1642 345637
Fax: +44 (0) 1642 345643
machinery@tuv-sud.co.uk
www.tuv-sud.co.uk

TÜV Product Service
TÜV SÜD Ltd
Belasis Business Centre
Coxwold Way
Billingham – TS23 4EA
United Kingdom

8 Contact Details

Reflex Marine Ltd (Head Office),
Old School House, School Hill,
Truro, TR4 9DU, UK

Telephone:

+44 (0)1872 321155

Email Addresses:

General enquiries

info@reflexmarine.com

Order enquiries (sales & replacement parts)

support@reflexmarine.com

Accounts Department

accounts@reflexmarine.com

Appendix I: Parts identification drawing and Torque settings

Drawing Number (Revision)	Description
RA0579(D)	Storm Work assembly
RP0604(A)	Storm Work torque setting and lubrication information
RA0641(B)	Storm Work Critical Parts Kit

1		2		3		4		5		6		7		8	
RA0579BOM															
REVISIONS															
ECN No.	REV.	DESCRIPTION										DATE	MODIFIED BY		
ECN-00466	D	BOM ITEM 34 LENGTH INCREASED TO 90mm										21-Sep-2018	Z.T.		
ECN-00425	C	BOM ITEM 3, 19 & 20 RAISED IN ISSUE										16-Nov-2017	J.O.		
ECN-00400	B	MULTIPLE BOM ENTRIES AMENDED. SEE DDM LONG DESCRIPTION.										12-Jul-2017	J.O.		

RA0579BOM				RA0579BOM			
ITEM NO.	PART NUMBER	DESCRIPTION	Default/QTY.	ITEM NO.	PART NUMBER	DESCRIPTION	Default/QTY.
1	RP0527	BUOYANCY PANEL, ROTOMOULDED POLYETHYLENE, FOAM FILLED	4	28	112-000-WA-4	M12 FLAT WASHER FORM A	92
2	RP0623	DOOR HINGE	2	29	112-000-NA-4	M12 AEROTIGHT NUT	46
3	RP0533	OUTER FRAME, SHORT	1	30	112-065-HB-4	M12x65 HEX BOLT	22
4	RP0541	INNER FRAME WELDMENT, SHORT	1	31	112-070-HB-4	M12x70 HEX BOLT	24
5	RA0607	DOOR ASSEMBLY	1	32	110-000-WA-4	M10 FLAT WASHER FORM A	16
6	RP0555	INNER FRAME WELDMENT, LONG	2	33	110-000-NA-4	M10 AEROTIGHT NUT	8
7	RP0556	WASHER PLATE, DOOR	2	34	110-090-HB-4	M10x90 HEX BOLT	8
8	RP0557	WASHER PLATE	6	35	108-000-WA-4	M8 FLAT WASHER FORM A	20
9	RP0558	ROOF BRACKET, LONG	2	36	108-000-NA-4	M8 AEROTIGHT NUT	10
10	RP0559	ROOF BRACKET, SHORT	2	37	108-055-SB-4	M8x55 SOCKET BUTTON HD SCREW	10
11	RP0618	STORM ROOF GRATING	1	38	105-000-WA-4	M5 FLAT WASHER FORM A	20
12	RP0561	GRP GRATING	1	39	105-000-NA-4	M5 AEROTIGHT NUT	12
13	RP0631	RUBBER FOOT WELDMENT	4	40	105-050-SK-4	M5x50 SOCKET COUNTERSUNK SCREW	12
14	RP0620	GRATING SUPPORT BEAM	2	41	1032-050-SP-2	M3.2x50 SPLIT COTTER PIN	4
15	RP0616	STORM LIFTING EYEBOLT, WLL 1 TONNE	4	42	116-050-WP-4	M16 PENNY WASHER OD50	16
16	RP0570	LIFT PLATE, UPPER	4	43	100-000-TS-4	TAMPER PROOF SEAL	4
17	RP0571	LIFT PLATE, LOWER	4	44	1048-016-RV-4	4,8 x 16 mm DOME HEAD RIVET, A4	8
18	RP0572	CORNER PLATE	4	45	106-000-NA-4	M6 AEROTIGHT NUT	10
19	RP0575	OUTER FRAME, DOOR	1	46	106-000-WA-4	M6 FLAT WASHER FORM A	12
20	RP0578	OUTER FRAME, LONG	2	47	106-020-SK-4	M6x20 SOCKET COUNTERSUNK SCREW	8
21	RP0589	GRATING WASHER	4	48	106-060-HB-4	M6x60 HEX BOLT	2
22	RP0617	ANTI-SNAG PLATE	4	49	116-000-NA-4	M16 AEROTIGHT NUT	8
23	RP0636	DOOR STRIKER	1	50	116-000-WA-4	M16 FLAT WASHER FORM A	4
24	RP0629	FOOT SPACER	4	51	116-000-WS-4	M16 SPRING WASHER RECTANGULAR TYPE B	4
25	RP0632	EYE NUT	4	52	116-000-NP-4	M16 HEX NUT	4
26	RP0633	NEOPRENE STRIP	4	53	116-070-HS-4	M16x70 HEX HEAD SCREW	4
27	RP0634	RUBBER STRIP	2				

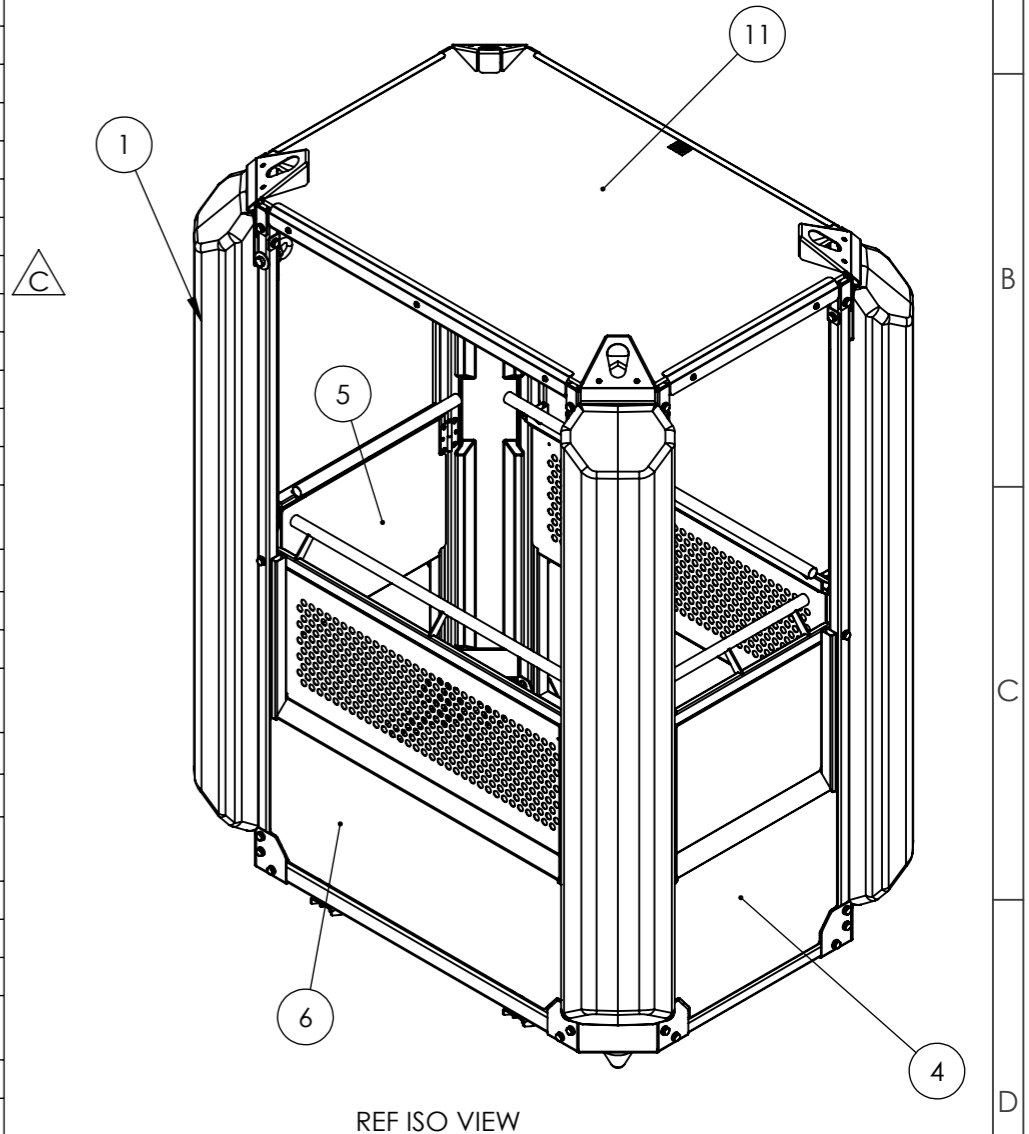

- NOTE:
1. REMOVE ALL BURRS AND SHARP EDGES
 2. TAG WITH DRAWING NUMBER AND REVISION
 3. SEE DRAWING RP0604 FOR TORQUE SETTINGS AND THREAD PREPARATION

Drawing status

Released

! IF IN DOUBT, PLEASE CONTACT engineering@reflexmarine.com

 3rd Angle Projection	All dimensions in millimetres unless otherwise stated	Drawing prepared in accordance with BS8888-2008 by RML Engineering Department. Any enquiries should be directed to engineering@reflexmarine.com		Created by J.O. on 09-Nov-2016	Approved by PO on 29-Nov-2016	
		Tolerances unless specified: 0 decimal places +/- 1 1 decimal place +/- 0.25 2 decimal places +/- 0.1 Angular +/- 1/4°	Estimated mass 323.10 kg	Title STORM WORK ASSEMBLY		
All diameters concentric 0.05 T.I.R.		Finish N/A	Material specification SEE PIECE PARTS			
Surface finish $\sqrt{3.2}$ μm all over U.O.S.		Surface treatment N/A	Drawing No. RA0579			
 www.reflexmarine.com This drawing, design and specification are the property of Reflex Marine Ltd and may not be reproduced or used in whole or part as the basis for sale. © 2016 Reflex Marine Ltd. Old School House, School Hill, Shortlanesend, Truro, Cornwall, TR4 9DU		Rev. D	Sheet 1 OF 5	Scale 1:20	Size A3	

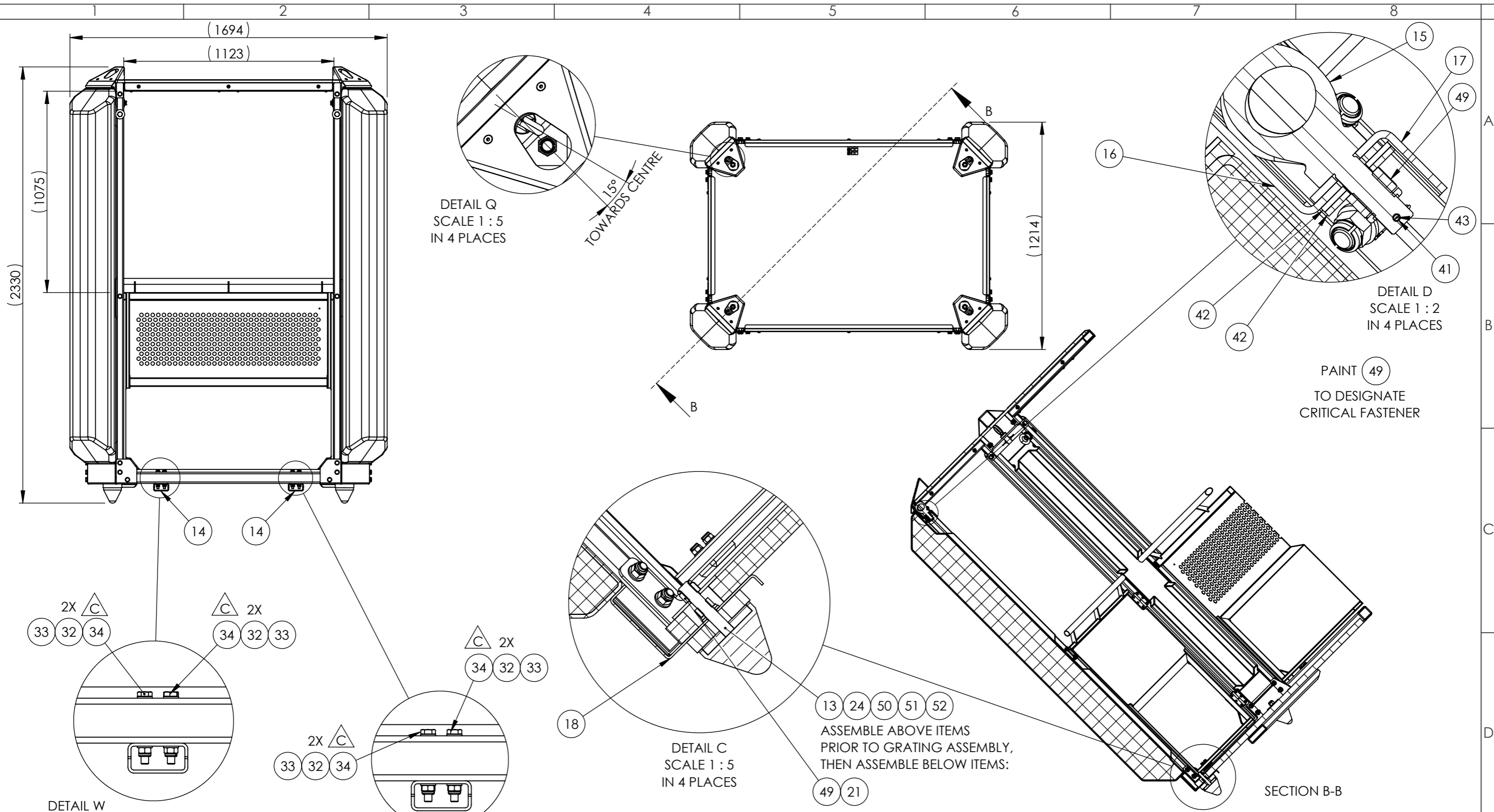

DETAIL W
SCALE 1 : 5
IN 2 PLACES

PAINT BOLT HEADS (ITEM (34))
TO DESIGNATE
CRITICAL FASTENERS

DETAIL X
SCALE 1 : 5
IN 2 PLACES

PAINT BOLT HEADS (ITEM (34))
TO DESIGNATE
CRITICAL FASTENERS

DETAIL C
SCALE 1 : 5
IN 4 PLACES

ASSEMBLE ABOVE ITEMS
PRIOR TO GRATING ASSEMBLY,
THEN ASSEMBLE BELOW ITEMS:

SECTION B-B

Drawing status
Released

! IF IN DOUBT, PLEASE CONTACT
engineering@reflexmarine.com

3rd Angle Projection All dimensions in millimetres unless otherwise stated Tolerances unless specified: 0 decimal places +/- 1 1 decimal place +/- 0.25 2 decimal places +/- 0.1 Angular +/- 1/4° All diameters concentric 0.05 T.I.R. Surface finish 3.2/μm all over U.O.S.	Drawing prepared in accordance with BS8888-2008 by RML Engineering Department. Any enquiries should be directed to engineering@reflexmarine.com	Created by J.O. on 09-Nov-2016	Approved by PO on 29-Nov-2016	
	Estimated mass 323.10 kg	Title STORM WORK ASSEMBLY		
Surface treatment N/A	Material specification SEE PIECE PARTS		Drawing No. RA0579	
 www.reflexmarine.com This drawing, design and specification are the property of Reflex Marine Ltd and may not be reproduced or used in whole or part as the basis for sale. © 2016 Reflex Marine Ltd. Old School House, School Hill, Shortlanesend, Truro, Cornwall, TR4 9DU	Rev. D	Sheet 2 OF 5		Scale 1:20

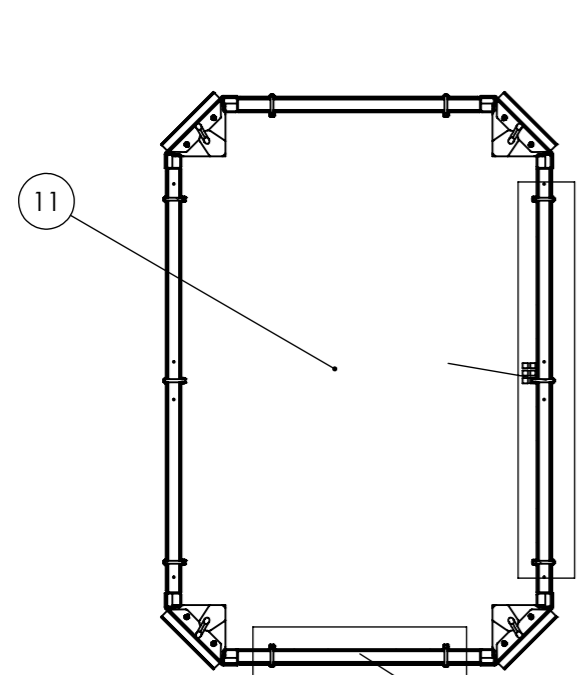

SECTION F-F
(640)

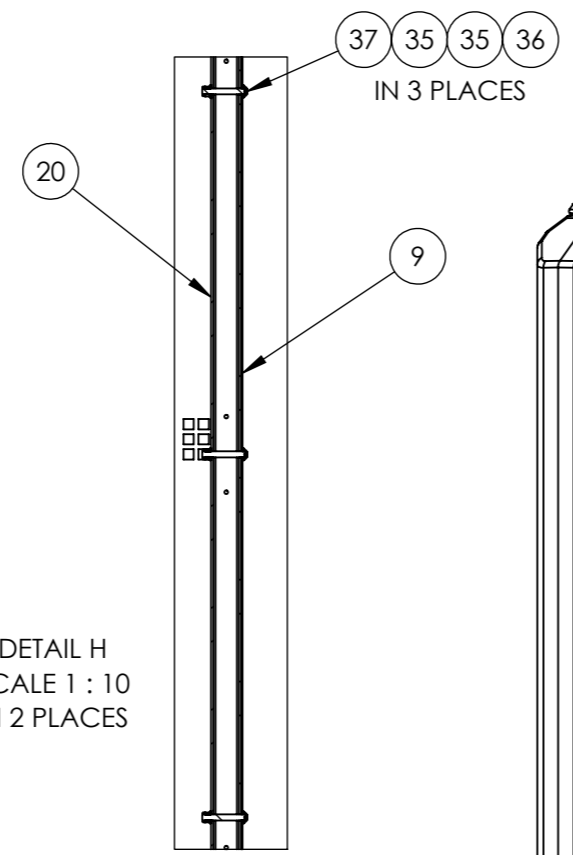
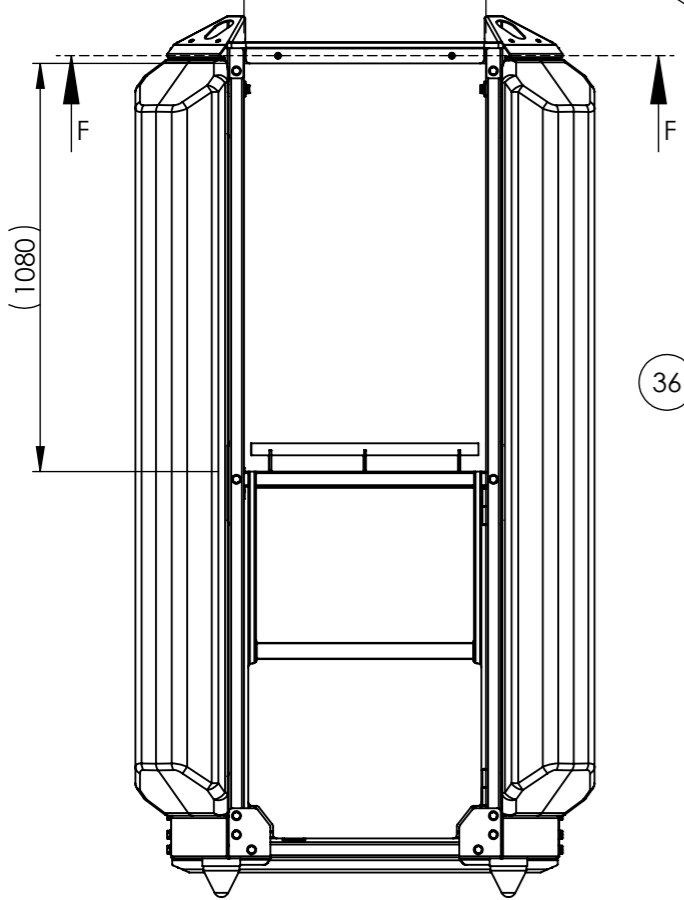

DETAIL H
SCALE 1 : 10
IN 2 PLACES

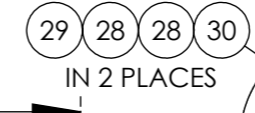
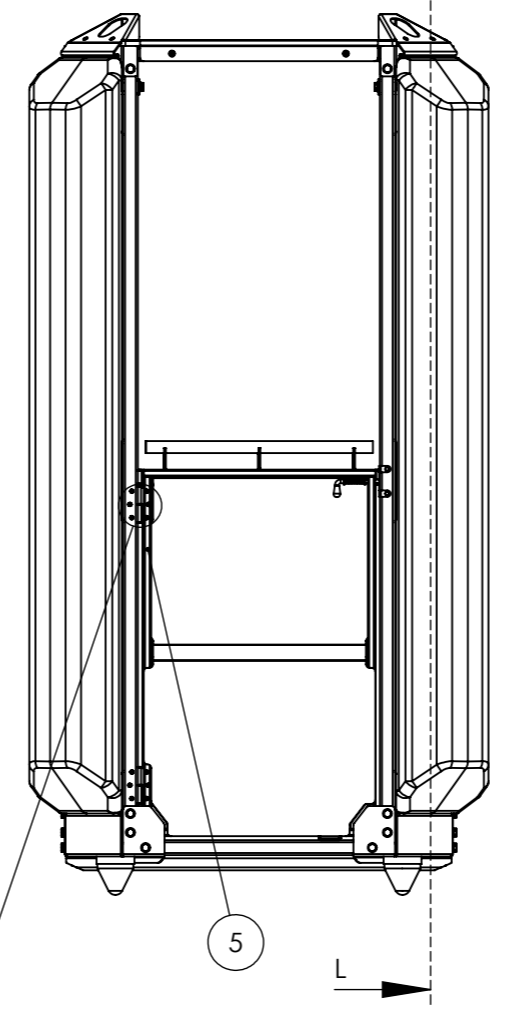

DETAIL T
SCALE 1 : 5
IN 4 PLACES

PAINT BOLT HEADS
(ITEM 30)
TO DESIGNATE
CRITICAL FASTENERS
(DETAIL T)

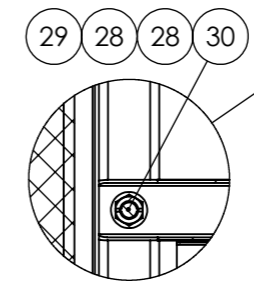

DETAIL R
SCALE 1 : 5
IN 4 PLACES

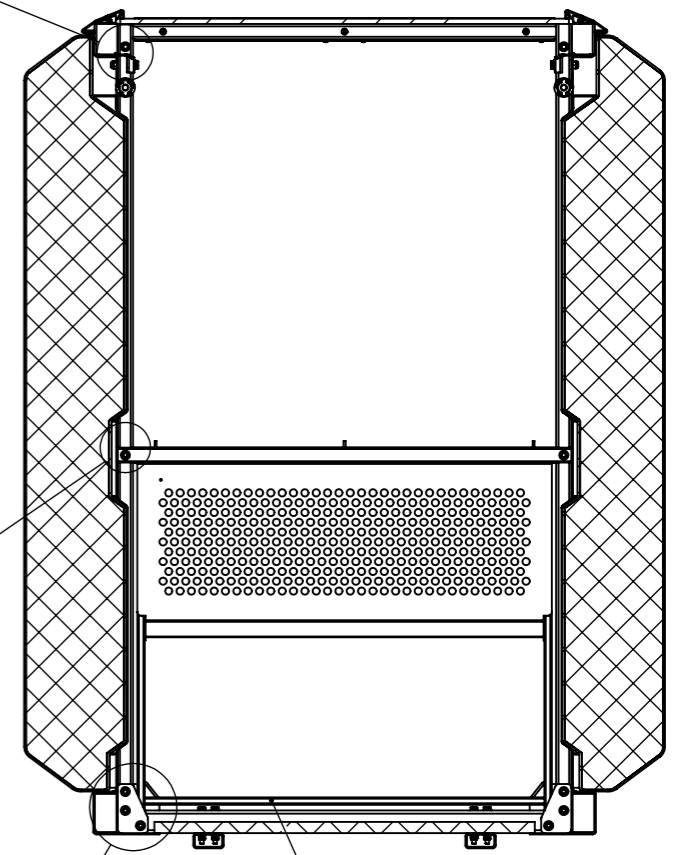

SECTION L-L

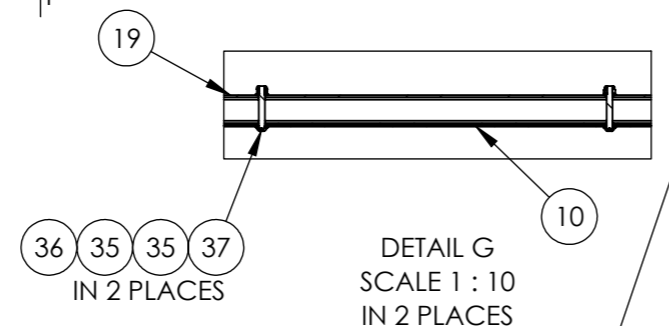

DETAIL G
SCALE 1 : 10
IN 2 PLACES

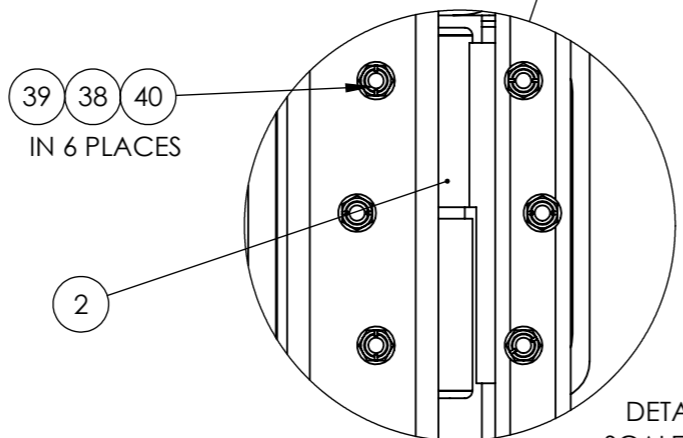

DETAIL I
SCALE 1 : 2
IN 2 PLACES

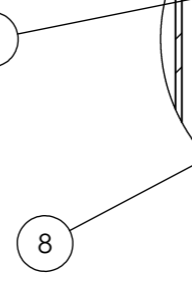

DETAIL M
SCALE 1 : 5
IN 4 PLACES

PAINT BOLT HEADS (ITEM 31)
TO DESIGNATE
CRITICAL FASTENERS

Drawing status
Released

! IF IN DOUBT, PLEASE CONTACT
engineering@reflexmarine.com

<p>3rd Angle Projection</p>	<p>All dimensions in millimetres unless otherwise stated</p>	<p>Drawing prepared in accordance with BS8888-2008 by RML Engineering Department. Any enquiries should be directed to engineering@reflexmarine.com</p>	<p>Created by J.O. on 09-Nov-2016</p>	<p>Approved by PO on 29-Nov-2016</p>	
	<p>Tolerances unless specified: 0 decimal places +/- 1 1 decimal place +/- 0.25 2 decimal places +/- 0.1 Angular +/- 1/4°</p>	<p>Estimated mass 323.10 kg</p>	<p>Title STORM WORK ASSEMBLY</p>		
<p>All diameters concentric 0.05 T.I.R.</p>	<p>Finish N/A</p>	<p>Material specification SEE PIECE PARTS</p>			
<p>Surface finish $\sqrt{3.2}$ μm all over U.O.S.</p>	<p>Surface treatment N/A</p>	<p>Drawing No. RA0579</p>			
<p>www.reflexmarine.com</p> <p>This drawing, design and specification are the property of Reflex Marine Ltd and may not be reproduced or used in whole or part as the basis for sale.</p> <p>© 2016 Reflex Marine Ltd. Old School House, School Hill, Shortlanesend, Truro, Cornwall, TR4 9DU</p>		<p>Rev. D</p>	<p>Sheet 3 OF 5</p>	<p>Scale 1:20</p>	<p>Size A3</p>

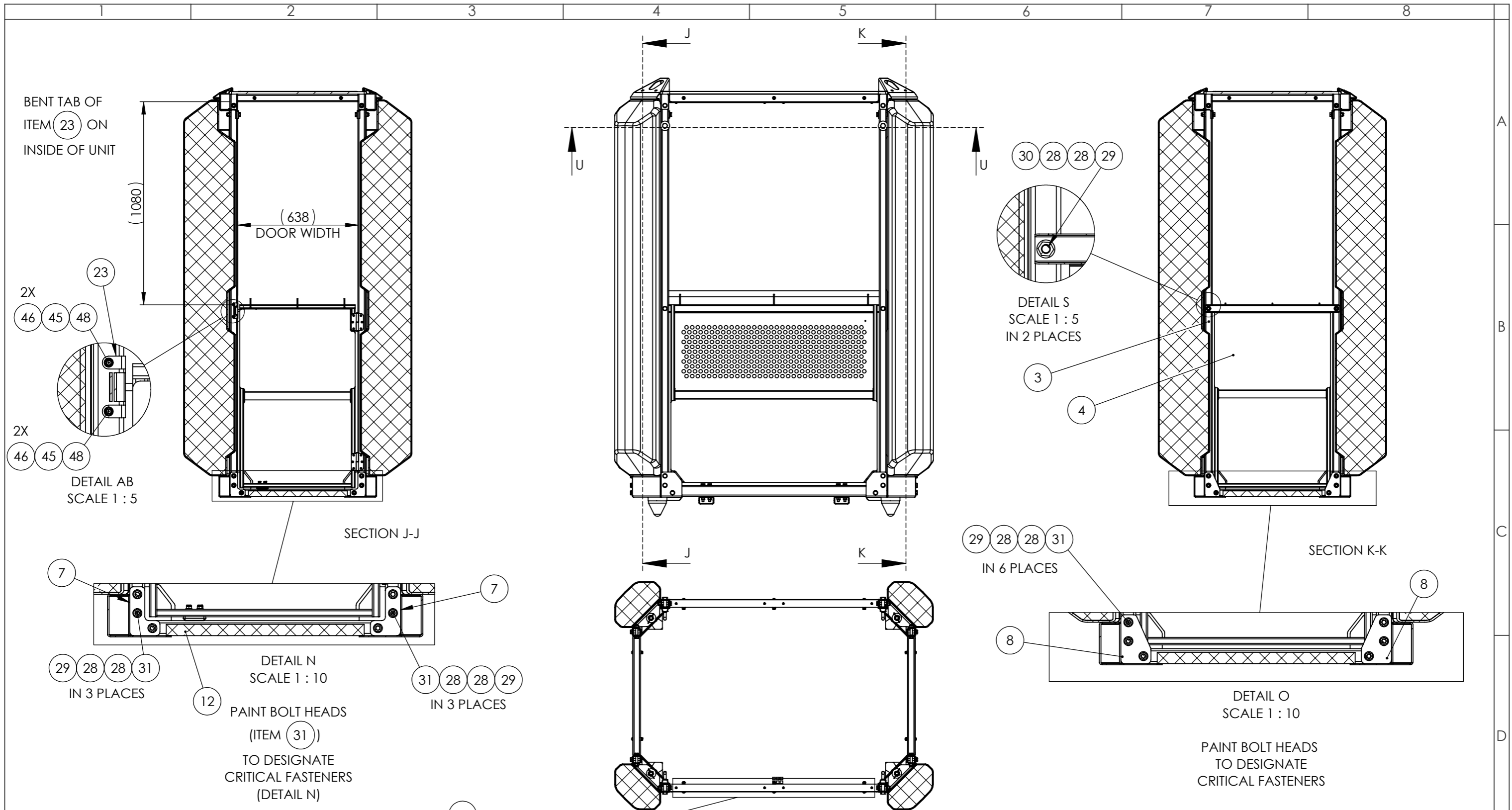

Drawing status
Released

DETAIL Y
SCALE 1 : 10
IN 2 PLACES

! IF IN DOUBT, PLEASE CONTACT
engineering@reflexmarine.com

3rd Angle Projection All dimensions in millimetres unless otherwise stated Tolerances unless specified: 0 decimal places +/- 1 1 decimal place +/- 0.25 2 decimal places +/- 0.1 Angular +/- 1/4° All diameters concentric 0.05 T.I.R. Surface finish 3.2/μm all over U.O.S.	Drawing prepared in accordance with BS8888-2008 by RML Engineering Department. Any enquiries should be directed to engineering@reflexmarine.com	Created by J.O. on 09-Nov-2016	Approved by PO on 29-Nov-2016
	Estimated mass 323.10 kg	Title STORM WORK ASSEMBLY	
Finish N/A	Material specification SEE PIECE PARTS		
Surface treatment N/A	Drawing No. RA0579		
Rev. D	Sheet 4 OF 5	Scale 1:20	Size A3

www.reflexmarine.com
 This drawing, design and specification are the property of Reflex Marine Ltd and may not be reproduced or used in whole or part as the basis for sale.
 © 2016 Reflex Marine Ltd.
 Old School House, School Hill, Shortlanesend, Truro, Cornwall, TR4 9DU

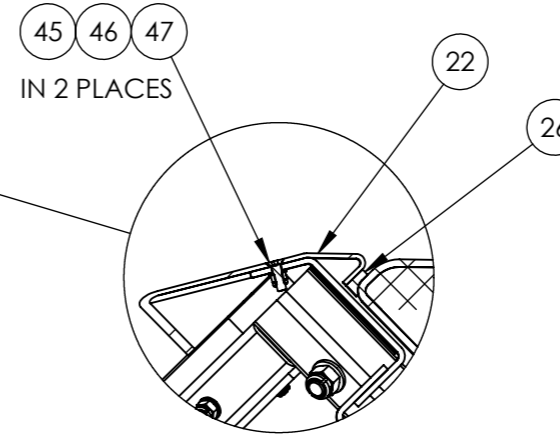
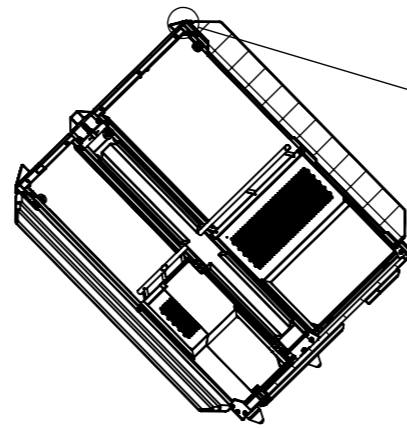
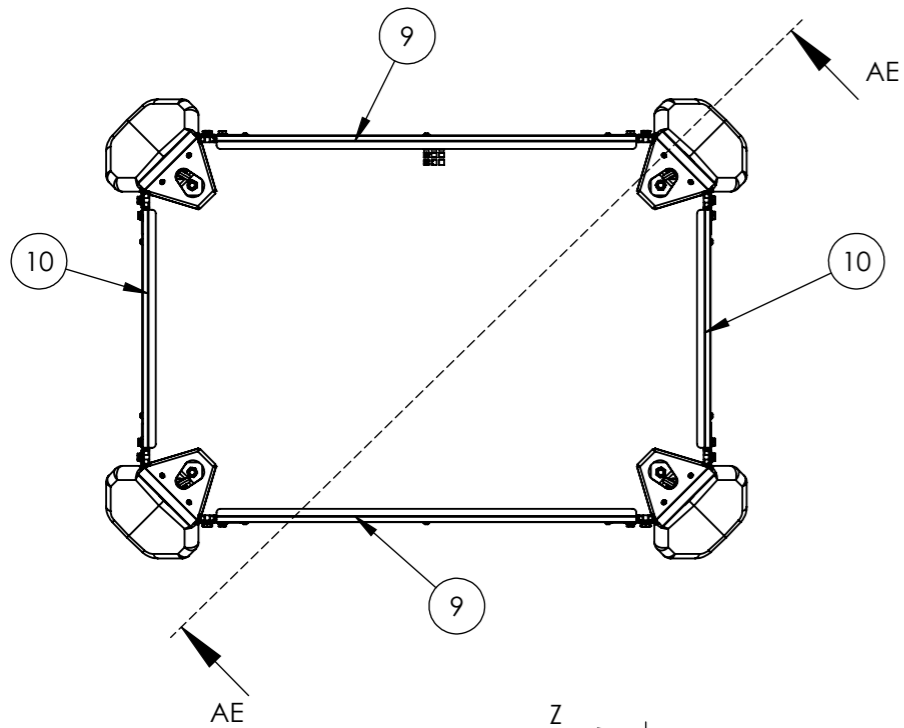

DETAIL AF
SCALE 1 : 5
IN 4 PLACES

ITEM 26 BONDED TO
ITEM 22 USING SIKAFLEX 252 OR 292
(AS PER ADHESIVE MANUFACTURER'S INSTRUCTIONS)

SECTION AE-AE
SCALE 1 : 50

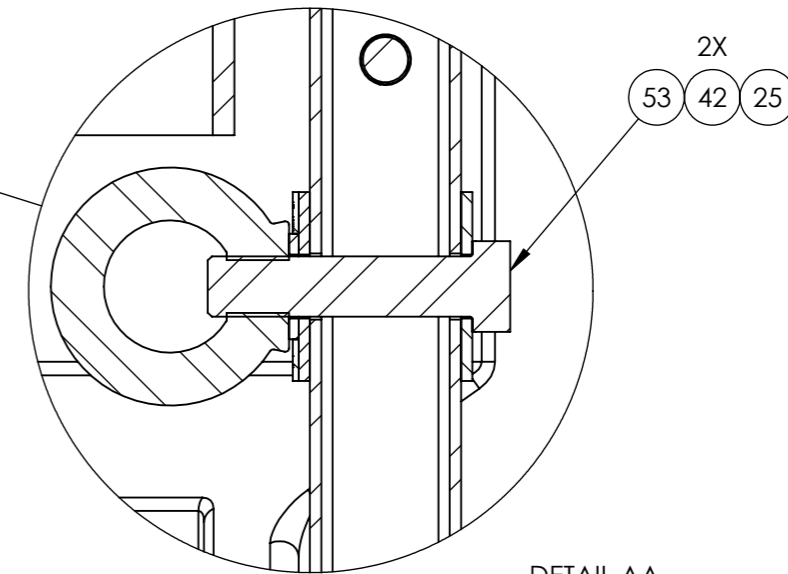
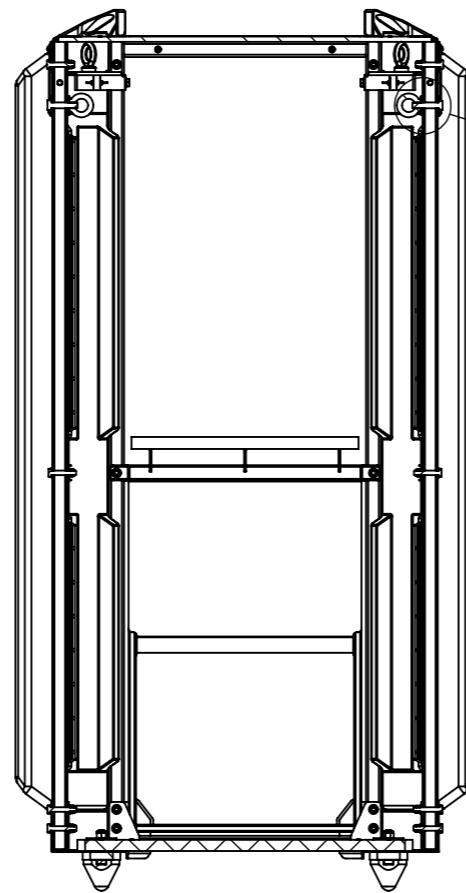
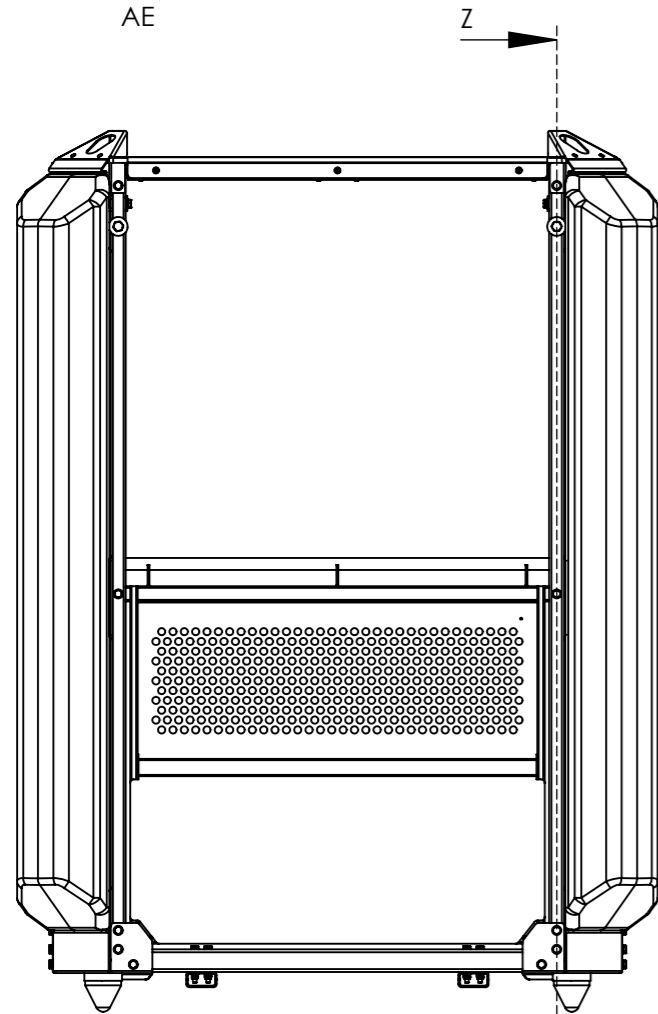

DETAIL AA
SCALE 1 : 2
IN 4 PLACES

SECTION Z-Z

Drawing status

Released

! IF IN DOUBT, PLEASE CONTACT
engineering@reflexmarine.com

3rd Angle Projection All dimensions in millimetres unless otherwise stated Tolerances unless specified: 0 decimal places +/- 1 1 decimal place +/- 0.25 2 decimal places +/- 0.1 Angular +/- 1/4° All diameters concentric 0.05 T.I.R. Surface finish $\sqrt{3.2}$ μm all over U.O.S.	Drawing prepared in accordance with BS8888-2008 by RML Engineering Department. Any enquiries should be directed to engineering@reflexmarine.com	Created by J.O. on 09-Nov-2016	Approved by PO on 29-Nov-2016		
	Estimated mass 323.10 kg	Title STORM WORK ASSEMBLY			
	Finish N/A	Material specification SEE PIECE PARTS			
	Surface treatment N/A	Drawing No. RA0579			
 www.reflexmarine.com This drawing, design and specification are the property of Reflex Marine Ltd and may not be reproduced or used in whole or part as the basis for sale. © 2016 Reflex Marine Ltd. Old School House, School Hill, Shortlanesend, Truro, Cornwall, TR4 9DU		Rev. D	Sheet 5 OF 5	Scale 1:20	Size A3

REVISIONS				
ECN No.	REV.	DESCRIPTION	DATE	MODIFIED BY
-	-	-	-	-
-	-	-	-	-
-	-	-	-	-

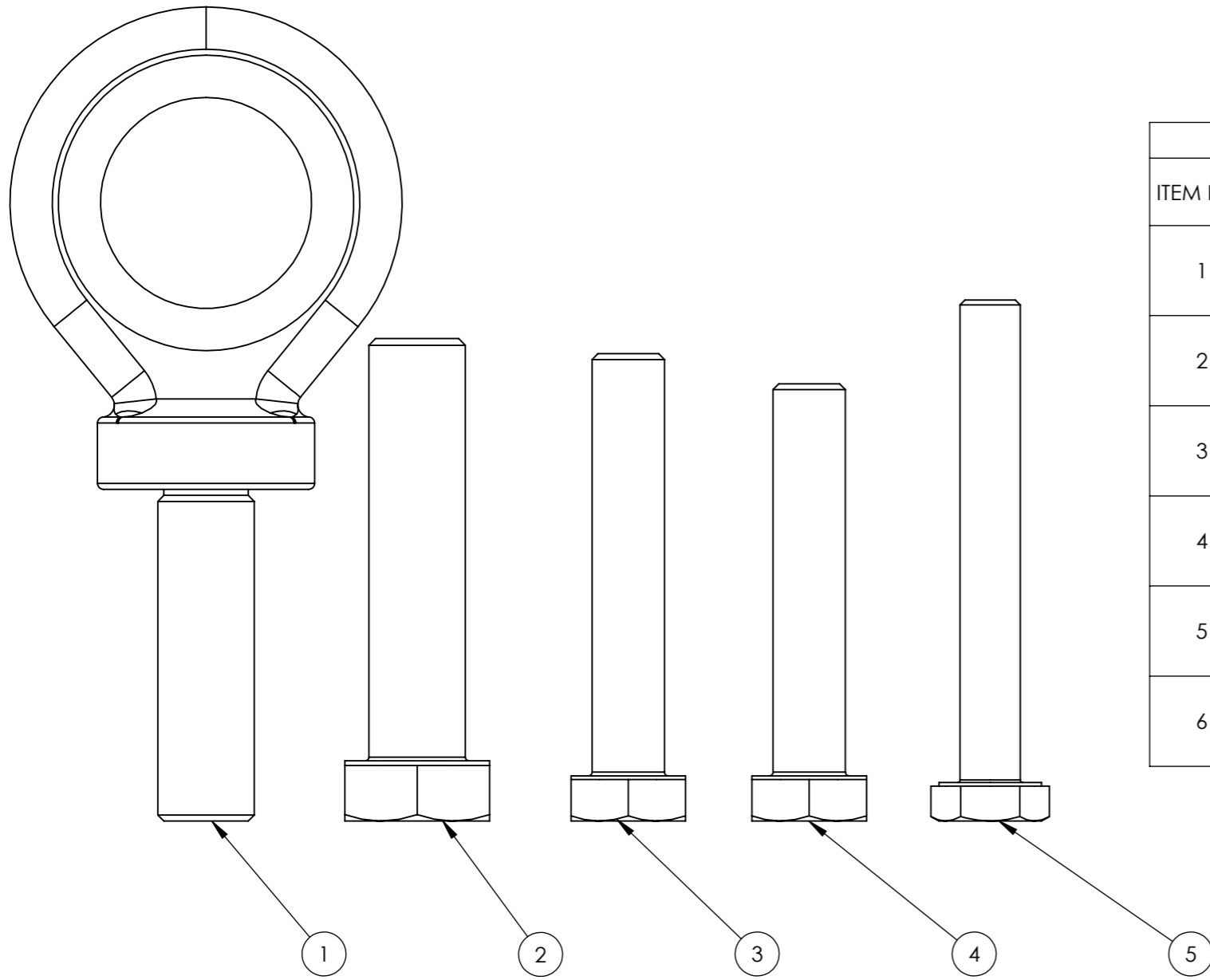

RP0604BOM				
ITEM NO.	PART NUMBER	DESCRIPTION	TORQUE SETTINGS	THREAD PREPARATION
1	RP0616	STORM LIFTING EYEBOLT, WLL 1 TONNE	50 Nm	SEE NOTE 1
2	116-070-HS-4	M16x70 HEX HEAD SCREW	150 Nm	SEE NOTE 1
3	112-070-HB-4	M12x70 HEX BOLT	42 Nm	SEE NOTE 1
4	112-065-HB-4	M12x65 HEX BOLT	42 Nm	SEE NOTE 1
5	110-080-HB-4	M10x80 HEX BOLT	24 Nm	SEE NOTE 1
6		ALL OTHER FASTENERS	WRENCH TIGHT	SEE NOTE 1

NOTE:

1. COPPER GREASE - COPASLIP HIGH TEMP ANTI-SEIZE COMPOUND/
ACTION CAN CS-90 COPPER ANTI-SEIZE GREASE WITH GRAPHITE/
ROCOL ANTI-SEIZE STAINLESS STEEL SPRAY/
EQUIVALENT
2. FOR TORQUE CALCULATIONS, SEE DOC-000290

Drawing status

Released

! IF IN DOUBT, PLEASE CONTACT
engineering@reflexmarine.com

 3rd Angle Projection	All dimensions in millimetres unless otherwise stated	Drawing prepared in accordance with BS8888-2008 by RML Engineering Department. Any enquiries should be directed to engineering@reflexmarine.com		Created by J.O. on 15-Nov-2016	Approved by PO on 11-Aug-2017
		Tolerances unless specified: 0 decimal places +/- 1 1 decimal place +/- 0.25 2 decimal places +/- 0.1 Angular +/- 1/4°	Estimated mass 0.66 kg	Title STORM WORK TORQUE SETTINGS AND LUBRICATION INFORMATION	
All diameters concentric 0.05 T.I.R.	Finish N/A	Material specification SEE PIECE PARTS			
Surface finish $\sqrt{3.2}$ μm all over U.O.S.	Surface treatment N/A	Drawing No. RP0604			
 www.reflexmarine.com This drawing, design and specification are the property of Reflex Marine Ltd and may not be reproduced or used in whole or part as the basis for sale. ©2016 Reflex Marine Ltd. Old School House, School Hill, Shortlanesend, Truro, Cornwall, TR4 9DU		Rev. A	Sheet 1 OF 1	Scale 1:1	Size A3

ITEM NO.	PART NUMBER	DESCRIPTION	QTY.
1	RP0616	STORM LIFTING EYEBOLT, WLL 1 TONNE	4
2	116-000-NA-4	M16 AEROTIGHT NUT	4
3	112-000-NA-4	M12 AEROTIGHT NUT	40
4	110-000-NA-4	M10 AEROTIGHT NUT	8
5	112-065-HB-4	M12x65 HEX HEAD BOLT	16
6	112-070-HB-4	M12x70 HEX BOLT	24
7	110-090-HB-4	M10x90 HEX BOLT	8
8	116-050-WP-4	M16 PENNY WASHER OD50	8
9	1032-050-SP-2	M3.2x50 SPLIT COTTER PIN	4
10	100-000-TS-4	TAMPER PROOF SEAL	4

△ B
△ B
△ B
△ B

REVISIONS				
ECN No.	REV.	DESCRIPTION	DATE	MODIFIED BY
ECN-00467	B	NOTE 3 AMENDED. BOM ITEM 7 LENGTH INCREASED. BOM ITEMS 8, 9, 10 ADDED.	22-May-2018	J.O.
-	-	-	-	-
-	-	-	-	-

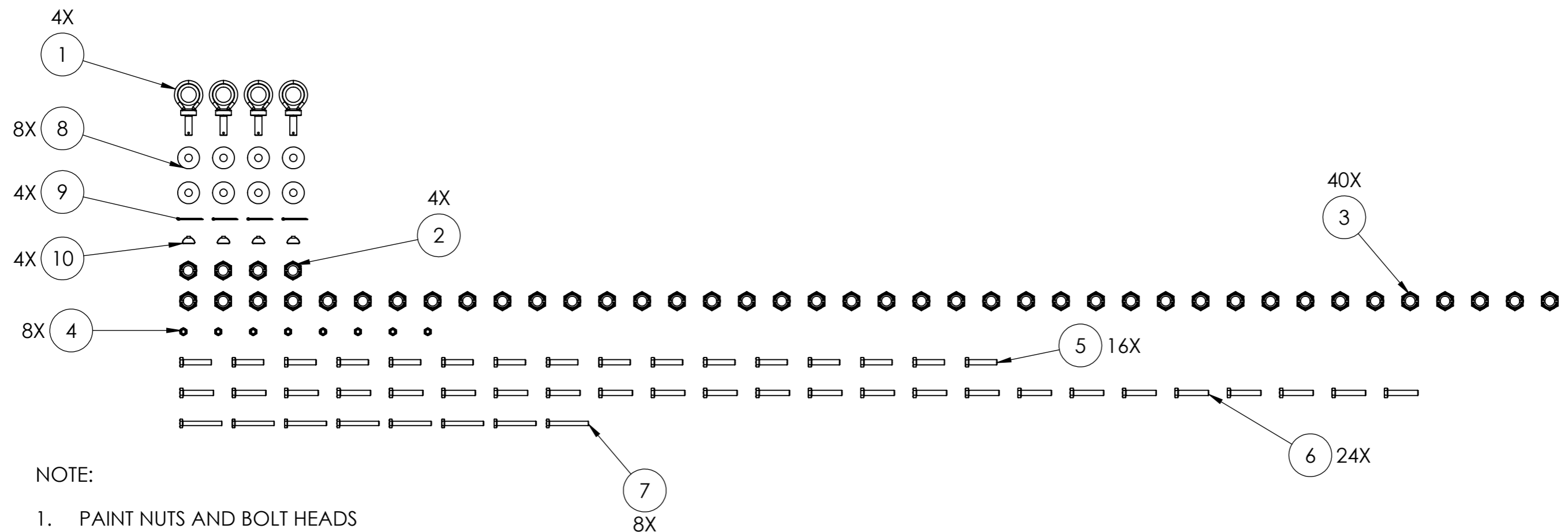

NOTE:

1. PAINT NUTS AND BOLT HEADS
2. SEE DRAWING RP0604 FOR TORQUE SETTINGS AND THREAD PREPARATION
3. **CERTIFICATION PACK (DOC-000510) TO BE COMPLETED AND PROVIDED WITH COMPONENTS**

△ B

Drawing status
Released

**! IF IN DOUBT, PLEASE CONTACT
engineering@reflexmarine.com**

 3rd Angle Projection	All dimensions in millimetres unless otherwise stated	Drawing prepared in accordance with BS8888-2008 by RML Engineering Department. Any enquiries should be directed to engineering@reflexmarine.com		Created by M.G on 05-Jul-2017	Approved by J.O. on 09-Jan-2018
		Tolerances unless specified: 0 decimal places +/- 1 1 decimal place +/- 0.25 2 decimal places +/- 0.1 Angular +/- 1/4°	Estimated mass 13.24 kg	Title STORM WORK CRITICAL PARTS KIT	
All diameters concentric 0.05 T.I.R.	Surface finish μm all over U.O.S.	Finish N/A	Surface treatment N/A	Material specification SEE PIECE PARTS	
 www.reflexmarine.com		Drawing No. RA0641		Rev. B	Sheet 1 OF 1
This drawing, design and specification are the property of Reflex Marine Ltd and may not be reproduced or used in whole or part as the basis for sale. © 2016 Reflex Marine Ltd. Old School House, School Hill, Shortlanesend, Truro, Cornwall, TR4 9DU		Scale 1:10	Size A3		